

KIT IVECO DAILY H2

DE	Montageanleitung für die Halterungen
EN	Installation instructions for brackets
FR	Instructions de montage pattes
ES	Instrucciones de instalacion de los estribos
IT	Istruzioni di montaggio staffe

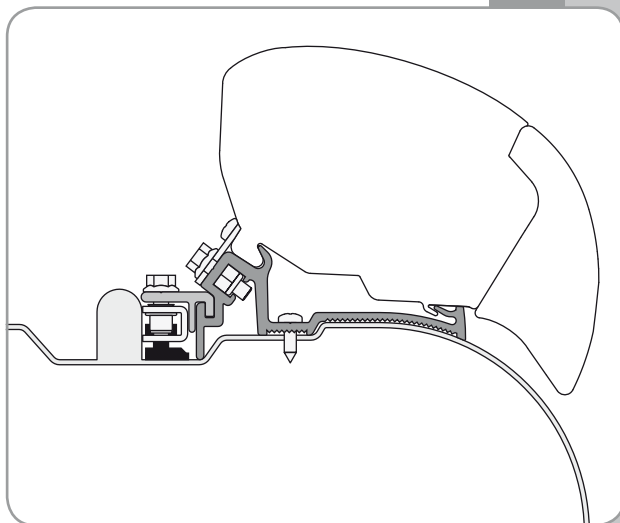

Fiamma F65

DE Verpackungsinhalt
FR Contenu de l'emballage
IT Contenuto dell'imballo

EN Package contents
ES Contenido del embalaje

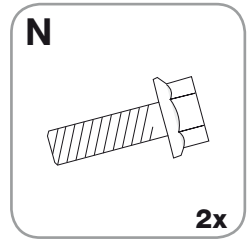
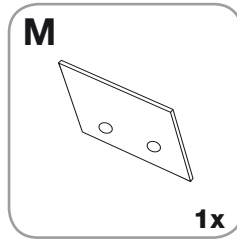
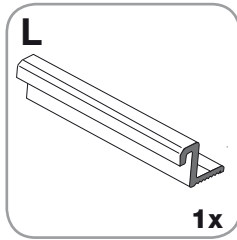
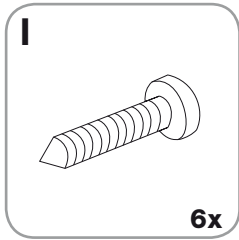
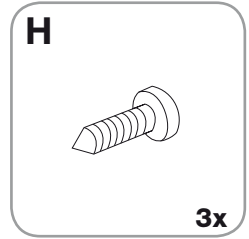
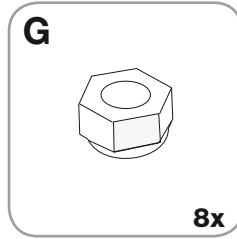
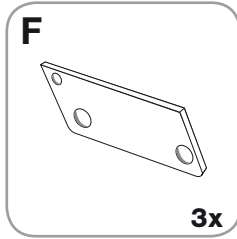
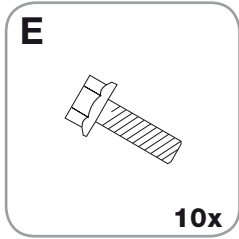
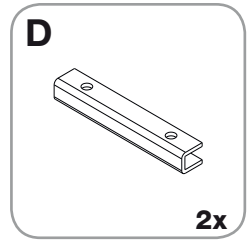
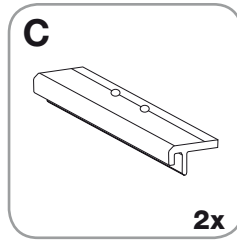
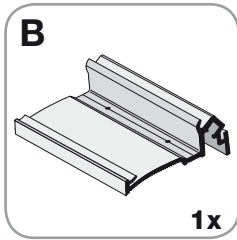
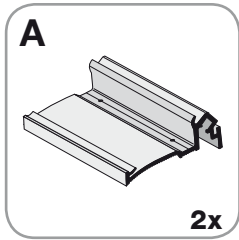
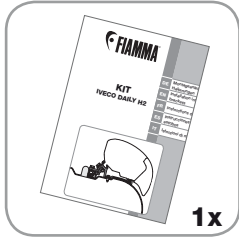

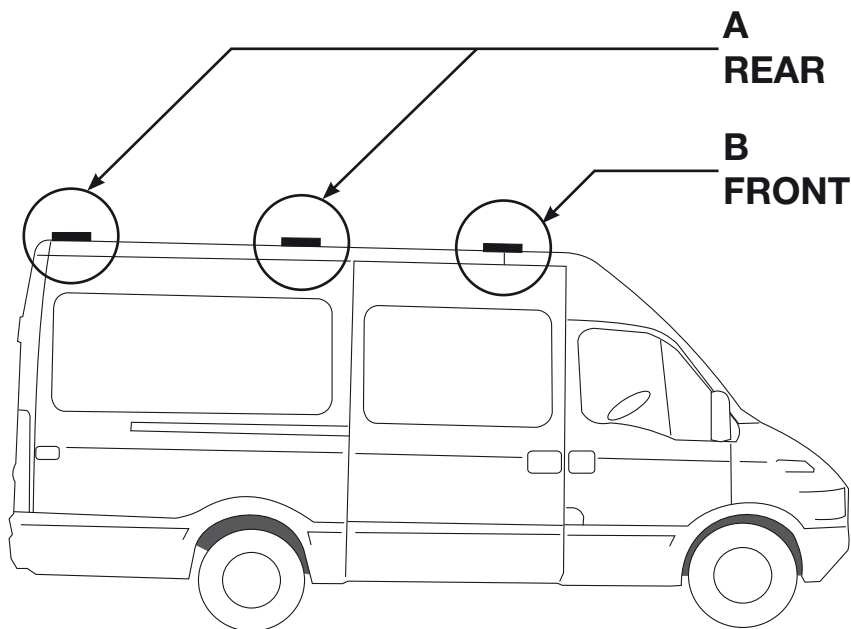

DE Beim Anbringen der Markise darauf achten, dass die Halterungen an den Markierungen "SUPPORT" und an den Anbringungspunkten der Arme im Gehäuse befinden

EN When installing the awning, please make sure that the brackets are in correspondence with the marking "SUPPORT" and in correspondence with the arms fixing points in the case box

FR Pendant l'installation du store, assurez-vous que les supports soient en correspondance du point de fixation des bras au boîtier

ES Antes que instalar el toldo, verificar que los estribos se encuentren a nivel de la escrita "SUPPORT" y por consiguiente a nivel del punto de fijación de los brazos el armazón

IT Verificare prima dell'installazione del tendalino, che le staffe si trovino in corrispondenza della scritta "SUPPORT" e di conseguenza in corrispondenza al punto di fissaggio delle braccia sul cassonetto

REAR

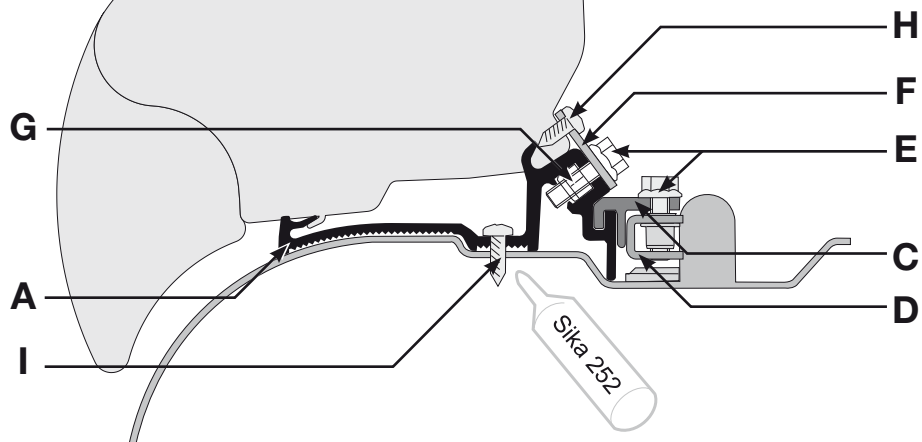

FRONT

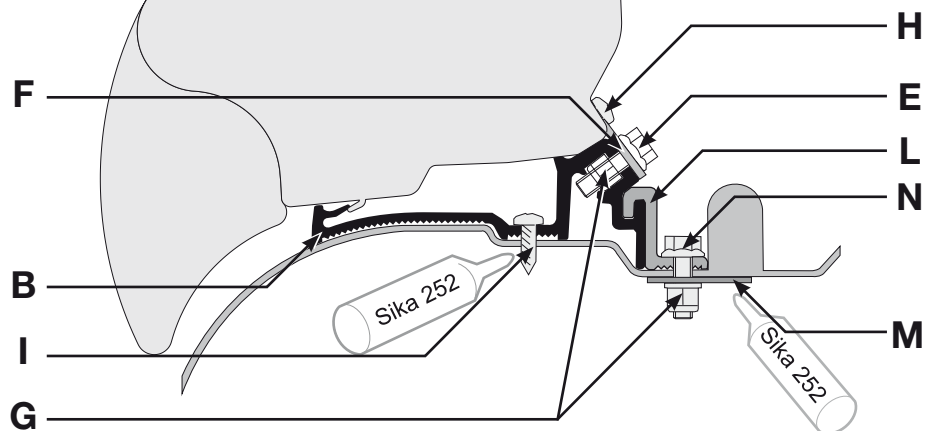

- DE** Anbringung der Halterungen am Fahrzeug
EN Installation of the brackets on the vehicle
FR Installation des pattes sur le véhicule
ES Instalación de los estribos sobre el vehículo
IT Montaggio delle staffe sul mezzo

REAR

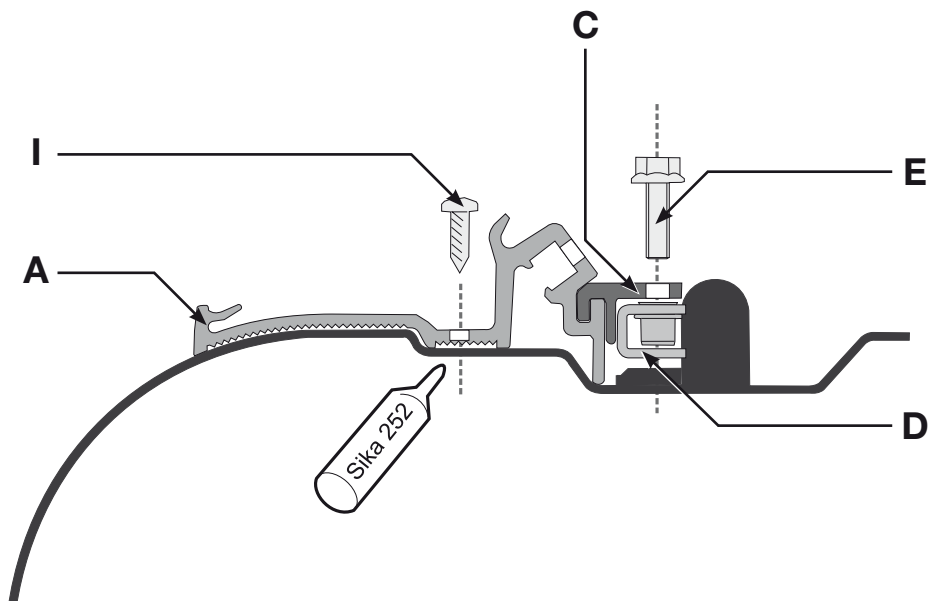
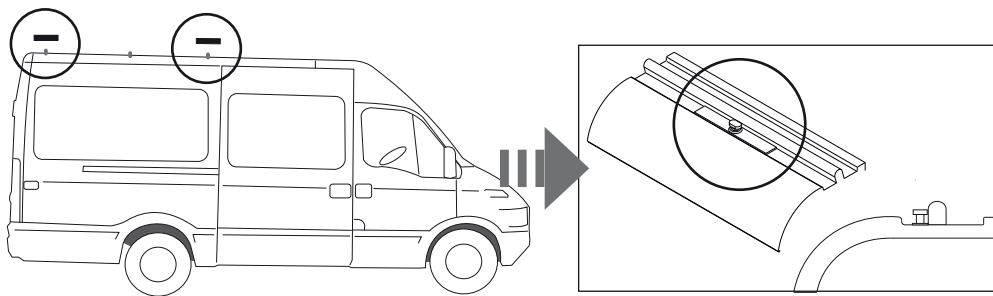

- DE** Anbringung der Halterungen am Fahrzeug
EN Installation of the brackets on the vehicle
FR Installation des pattes sur le véhicule
ES Instalación de los estribos sobre el vehículo
IT Montaggio delle staffe sul mezzo

FRONT

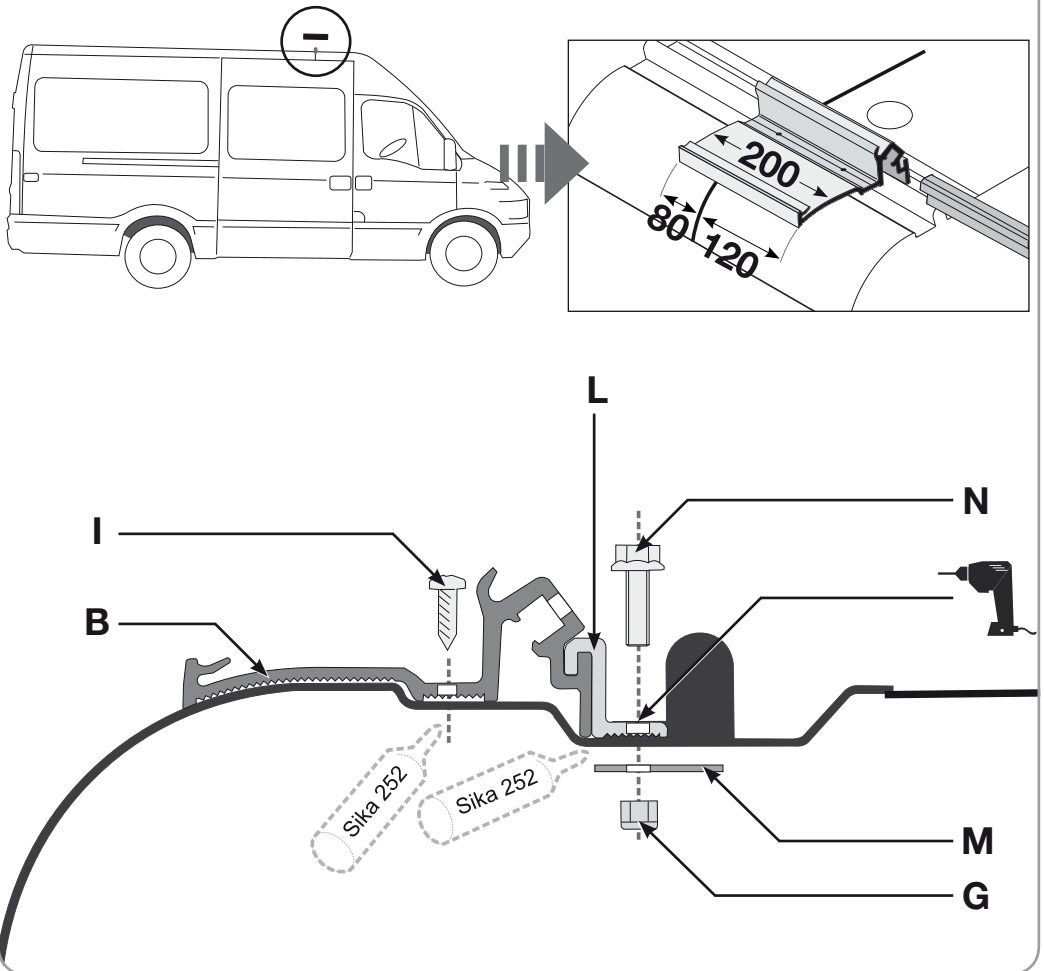

DE Anbringung der Markise auf die Halterungen

EN Installation of the awning on the brackets

FR Installation du store sur les pattes

ES Fijación del toldo sobre los estribos

IT Montaggio del tendalino sulle staffe

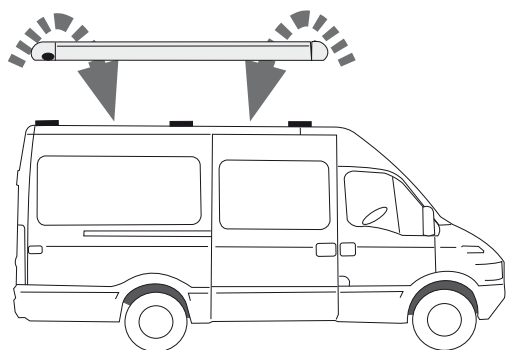

FRONT

REAR

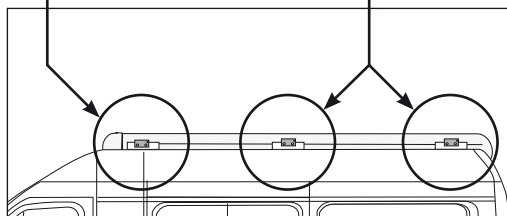

DE **Achtung Sicherheit:** entfernen Sie die Etikette nur nachdem die Markise mit der Halterung befestigt wird

EN **Attention Security:** remove this label only after fixing the awning to the bracket

FR **Attention Sécurité :** lever l'étiquette seulement après la fixation du store à l'étrier

ES **Atención Seguridad:** quitar esta etiqueta de seguridad solo después de fijar el toldo sobre el estribo

IT **Attenzione Sicurezza:** rimuovere questa etichetta di sicurezza solo dopo aver fissato il tendalino sulla staffa

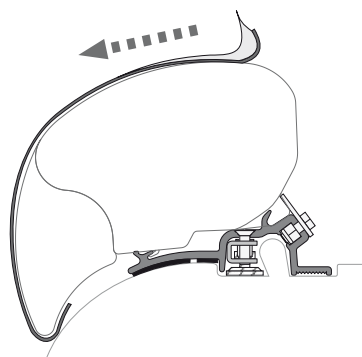

DE Montageanleitung
FR Instructions de montage
IT Istruzioni di montaggio

EN Installation instructions
ES Instrucciones de montaje

DE Anbringung der Markise auf die Halterungen
EN Installation of the awning on the brackets
FR Installation du store sur les pattes
ES Fijación del toldo sobre los estribos
IT Montaggio del tendalino sulle staffe

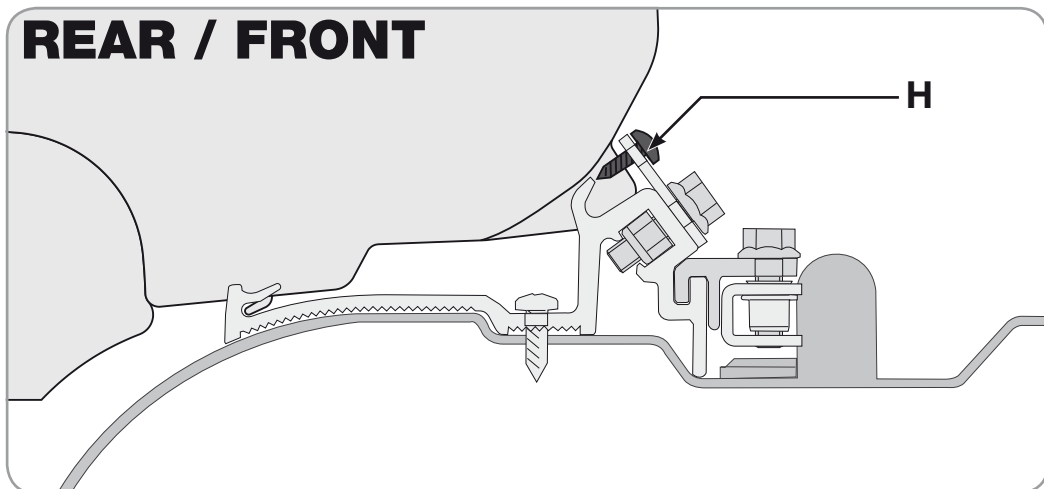

DE Bitte immer die Sicherheitsschrauben benutzen
EN Please use always the security screw
FR Utilisez toujours les viss de sécurité
ES Poner siempre los tornillos de seguridad
IT Mettere sempre le viti di sicurezza

DE **ACHTUNG** Regelmäßig die Befestigung für die Halterungen kontrollieren. Achten Sie vor allem nach den ersten Kilometern darauf, dass sich die Haltebügel nicht verschoben haben

EN **ATTENTION** Periodically check the brackets to make sure they are firmly attached (especially after the first kilometers) make sure the bolts are not loose and that holding brackets have not shifted

FR **ATTENTION** Contrôler périodiquement l'état de fixation des pattes (surtout après les premiers kilomètres) en s'assurant que les supports de fixation n'aient pas bougé

ES **CUIDADO** Controlar periódicamente el estado de fijación de los estribos (sobre todo después de los primeros Kms) asegurándose que no se desplacen

IT **ATTENZIONE** Controllare periodicamente lo stato di fissaggio delle staffe (soprattutto dopo i primi chilometri) assicurandosi che le stesse non si siano mosse e che i serraggi siano corretti

DE Bitte halten Sie sich beim Gebrauch für die Markise an die Gebrauchsanweisung

EN When using the awning please follow the instructions of the product

FR Pour l'utilisation du store, se référer aux instructions du store même

ES Para el uso del toldo, atenerse a las instrucciones que se encuentran en el producto

IT Per l'utilizzo del tendalino, attenersi alle istruzioni presenti nel prodotto

DE

Im Falle einer Vertragswidrigkeit der Ware, kann der Verbraucher unter den erforderlichen Voraussetzungen gegenüber dem Verkäufer von dem Garantieanspruch zu den festgelegten Bedingungen gemäss den lokalen Rechtsvorschriften Gebrauch machen

EN

In case of defects with regards to materials and manufacturing, the customer is entitled to the warranty in accordance with local laws and regulations of the country in which the product was purchased

FR

En cas d'un défaut de conformité du produit, le consommateur pourra faire valoir ses droits de recours en garantie selon les modalités prévues par les dispositions légales locales, pour autant que les conditions de recours soient remplies

ES

En caso de fallos o defectos de material y de fabricación, el cliente puede hacer valer la garantía de acuerdo con las leyes y reglamentaciones del país en el que el producto haya sido comprado

IT

In caso di difetto di conformità dei beni, il consumatore potrà far valere nei confronti del venditore la garanzia secondo le modalità previste dalle disposizioni di legge locali, ove ne ricorrano i presupposti



fiamma.com

All rights reserved.

Fiamma S.p.A. reserves the right to modify at any time, without notice, prices, materials, specifications and models or to cease production of any model.

98655-733

RO_IS_98690-033_revD

Fiammastore

Fiamma SpA - Italy
Via San Rocco, 56
21010 Cardano al Campo (VA)